

System 450™ Series Modular Controls

Product Bulletin

C450xxx-x

Code No. LIT-12011458
Issued October 2018

Refer to the [QuickLIT website](#) for the most up-to-date version of this document.

Introduction

System 450™ is a family of modular, digital electronic controls that is easily assembled and set up to provide reliable temperature, pressure, and humidity control for a wide variety of HVACR applications, commercial process applications, and industrial process applications.

The System 450 control system is designed to replace System 350™ and System 27 control systems, and to provide many additional features and benefits with fewer than twenty model variations.

System 450 control modules provide a field-configurable out-of-the-box solution. Most System 450 control modules can control temperature, pressure, and humidity systems simultaneously.

A single C450 control module can be set up as a stand-alone control or connected to expansion modules to control up to ten On/Off relay and proportional analog outputs, based on any of the three available inputs.

System 450 control modules with communications enable you to connect System 450 control systems to MODBUS® or Ethernet networks for remote monitoring and setup. The MODBUS communications control module is an RS485, RTU compliant slave device. The Ethernet communications control module has an integral web server that can deliver web pages by using a direct connection, on your LAN, or across the Internet.

Figure 1: System 450 Control System with Control, Power, and Expansion Modules



System 450 reset control modules provide many of the features of the standard models for temperature and humidity control. In addition, these modules provide setpoint reset, real-time setback scheduling, and run-time balancing (equal run time) capability.

The System 450 control module with hybrid analog output has a single self-selecting analog output to optimize and extend the controlled speed range of variable speed electronically commutated (EC) motors.



Features and Benefits

- **Durable, Compact, Interchangeable Modular Components with Plug-Together Connectors and DIN Rail or Direct Wall Mount Capability**—Eliminate field wiring between modules and allow you to quickly and easily design, assemble, install, and upgrade your control systems.
- **Versatile, Multipurpose, Field-Configurable Control Modules and Expansion Modules Designed for Global Use**—Allow you to create a wide variety of application-specific control systems capable of controlling temperature, pressure, or humidity, or all three conditions simultaneously, with only a small suite of module models.
- **Control Modules with Bright Backlit LCDs and Four-Button Touchpad User Interfaces, Up to Three Hard-Wired Input Sensors and Up to Ten Relay or Analog Outputs (In Any Combination) per Control System**—Provide quick, clear, visual status of your System 450 control system inputs and outputs with the touch of a button and enable you to quickly and easily set up and adjust your control system.
- **An Extensive Suite of Compatible Temperature and Humidity Sensors and Pressure Transducers**—Allows you to monitor and control a wide range of HVACR and process conditions in a variety of standard and global units of measurement.
- **Differential Control**—Enables your control system to monitor and maintain a temperature, pressure, or humidity differential between two sensor points within a system, process, or space.
- **On/Off Delays**—Allow the user to configure an on delay (the time between a setpoint trip and the energizing of a relay) and an off delay (the time between a setpoint trip and the de-energizing of a relay).

Overview

The System 450 Series is a family of compact digital electronic control, expansion, and power modules that are easily assembled and set up to provide reliable on/off and proportional control of temperature, pressure, and humidity conditions in a wide variety of HVACR applications, commercial process applications, and industrial process applications.

A System 450 Series control system includes:

- a single System 450 control module with LCD and 4-button touchpad
- one to three inputs
- one to ten relay and/or analog outputs (provided by the control module and expansion modules)
- an optional power module

Compact Modular Plug-Together Design

All System 450 modules feature a compact, durable, gray LEXAN® housing with DIN rail clips and slotted mounting holes molded into the back of the housing for easy installation.

System 450 modules also feature 6-pin connectors on the sides of the housing, enabling easy assembly and upgrade of your control systems and eliminating the need for field wiring between modules.

A System 450 control system provides compact, clean, and consistent control system assemblies that are simple to build, install, and maintain.

Multipurpose and Field-Configurable Design

System 450 control, expansion, and power modules are multipurpose devices that can be easily configured in the field to control temperature, pressure, and humidity, simultaneously.

Global Design

A System 450 control system is the next generation of System 350 and System 27 modular controls, but the System 450 modular control system, with fewer than twenty model variations, provides far more features and flexibility than either the System 350 modular control system (54 models) or the System 27 modular control system (40 models).

System 450 modules are designed, tested, and certified for global application and are Underwriters' Laboratories, Inc. (cULus) Listed and CE compliant.

System 450 control systems can be set up in standard units of measurement used worldwide: Fahrenheit, Celsius, psi, bar, inches water column (in. W.C.), and relative humidity (RH).

Control Capabilities

A System 450 control system offers a variety of control capabilities, depending on the model selected. See Table 1 for information on System 450 control modules with specific features.

On/Off Relay Control

Relay outputs provide low and line-voltage on/off control for devices and equipment in your controlled systems. Each relay output is a single-pole, double-throw (SPDT) set of dry contacts.

Note: System 450 output relays are SPDT dry contact relays only and do **not** provide any power source for your controlled equipment.

See [Technical Specifications](#) for output relay electrical rating information. See Table 1 for information on the System 450 control modules with this feature.

Analog Proportional Control

Analog outputs provide proportional analog signals for devices and equipment in your controlled systems. Each analog output can generate either a 4 to 20 mA or 0 to 10 VDC signal. The output signal type is self-selecting; after you connect the analog output to the controlled equipment, the output detects the analog input on the controlled equipment and generates the appropriate analog signal for the connected input.

You can set up an analog output to generate a direct acting or reverse acting proportional output signal. You can also set up the output signal strength to increase or decrease in either the direct acting or reverse acting mode. See the example in Figure 4.

An analog output's control action is automatically determined by the setup values you select for the Setpoint, End Point, % Output at Setpoint, and % Output at Endpoint values when you set up the output in the UI.

An indicator (control ramp) appears on the output status screen for each analog output to represent the analog output's control action.

Figure 2: Proportional Analog Output Operation for Room Heating (Reverse Acting) Application

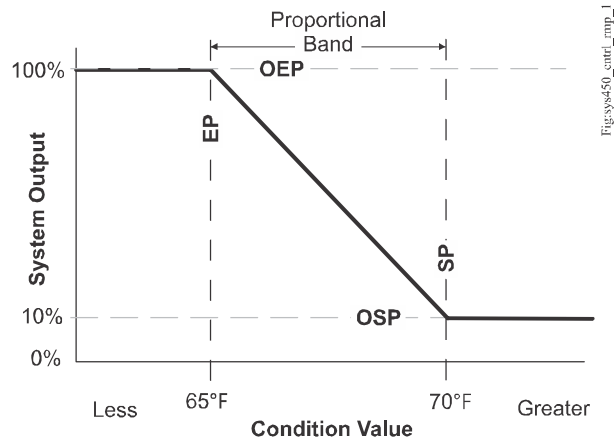

Sensor Type = °F
Setpoint (SP) = 70 (°F)
Endpoint (EP) = 65 (°F)
Setpoint (SP) > Endpoint (EP)
Output at Setpoint (OSP) = 10 (%)
Output at Endpoint (OEP) = 100 (%)

See Table 1 for information on the System 450 control modules with this feature.

Proportional Plus Integral Control

In addition to standard proportional (only) control analog signals, a System 450 control system provides integral control capability and six time integral selections that enable you to set up analog outputs to generate a proportional plus integral signal.

Proportional plus integral (PI) control incorporates a time-integral control action with proportional control action. Therefore, if properly set up, a PI control loop can effectively eliminate offset error and enable a controlled system to drive much closer to the desired setpoint, even under large constant loads. On a properly sized system with predictable loads, PI control can maintain the controlled system very close to setpoint.

The integration constant that you select establishes the rate at which the control readjusts the analog output signal. The faster the integration constant, the faster the control readjusts the output signal, and the faster the recovery rate of a properly sized and setup control loop. See Table 1 for information on the System 450 control modules with this feature.

Multistage On/Off and Proportional Control

You can set up multiple outputs to create a variety of equipment staging control systems. Depending on the control module and expansion modules, a System 450 multistage application may use On/Off control (relay outputs) or proportional control (analog outputs). See Table 1 for information on the System 450 control modules with this feature.

High Input Signal Select

The High Input Signal Selection feature enables a System 450 control system to monitor a condition (temperature, pressure, or humidity) with two or three sensors (of the same type) and control relay and analog outputs based on the highest condition value sensed. See Table 1 for information on the System 450 control modules with this feature.

Differential Control

The Differential Control feature enables a System 450 control system to monitor and maintain a temperature, pressure, or humidity differential between two sensors of the same type. This feature also enables the control system to control relay outputs, analog outputs, or a combination of relay and analog outputs, based on the sensed differential value relative to user-selected differential values. An example is the water pressure drop across an in-line water filter. See Table 1 for information on the System 450 control modules with this feature.

Reset Control

System 450 reset control modules automatically adjust the setpoint for a supply control loop, based on input from the master (outdoor/ambient) sensor and the user-selected reset setpoint settings. This saves energy by using only the required capacity of the supply to heat, cool, dehumidify, or humidify the desired space or environment.

See Figure 3 for an example of Setpoint Reset Control for both a chilled water temperature reset application and a boiler water temperature reset application. See Table 1 for information on the System 450 control modules with this feature.

Figure 3: Reset Setpoint Application for Boiler Water Supply (BWS) and Chiller Water Supply (CWS) Showing Relationships between the Reset

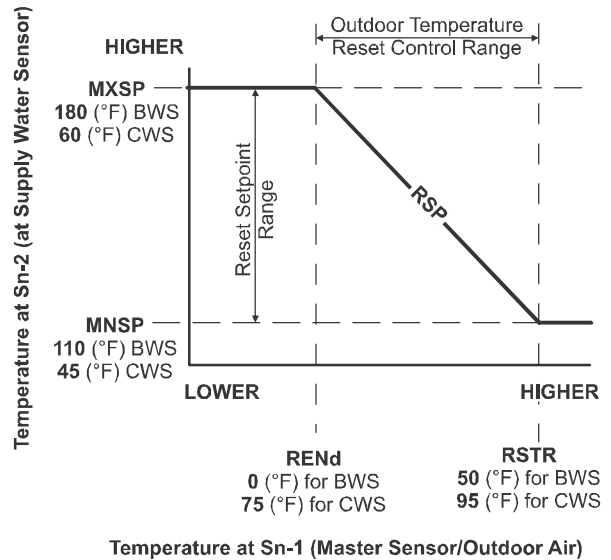

- MNSP** = Minimum Reset Setpoint
- MXSP** = Maximum Reset Setpoint
- RSTR** = Reset Setpoint Start Temperature
- RENd** = Reset Setpoint End Temperature
- RSP** = Calculated (Floating) Reset Setpoint

FIG:sys450_RSTP_sfp

Setback Scheduling

The reset control module's real-time clock allows you to schedule outputs by day of week and time of day. You can also set up setback temperatures (and humidity) to create an occupied/unoccupied setback schedule for the outputs in your control system. You can select a negative setback value for heating or humidification, or a positive setback value for cooling or dehumidification control. See Table 1 for information on the System 450 control modules with this feature.

Run-Time Balancing

The reset control module's run-time balancing feature enables your control system to even out the runtimes of staged equipment by automatically selecting the stage with the smallest runtime when responding to increases in the system load. Run-time balancing allows control of up to four staged outputs. See Table 1 for information on the System 450 control modules with this feature.

Analog Output Signal Limiting

The analog output signal limiting feature on the System 450 control modules with communications reduces the rate at which an analog output updates its output signal strength in response to input signal changes. When controlling a device such as a modulating actuator, the analog output signal limiting feature can help lengthen actuator life by reducing the actuator position update frequency. This feature is controlled by two parameters:

- **Output Signal Update Rate** allows you to select the rate (in seconds) at which an analog output updates the output signal to the controlled equipment
- **Output Signal Dead Band** allows you to create a deadband for the analog output signal within which the output signal strength remains constant

See Table 1 for information on the System 450 control modules with the analog output signal limiting feature.

Binary Input Control for Relay Outputs

You can connect a binary input (a user-supplied pair of dry contacts) to any of the three control module input terminals and control the output relays in your control system based on the binary input's state (open or closed). Examples of dry contacts include door switches, timers, occupancy sensors, and many more switching devices.

A sensor set up as a binary input can be referenced only by a relay output. Analog outputs cannot reference sensors set up as binary inputs.

On/Off Duration Time Control

Four time control parameters on the control modules with communications allow you to set up the relay outputs with On or Off time delays and minimum On or Off times. Each of the four On or Off duration control parameters can be set up for 0 to 300 seconds (5 minutes) in 1-second intervals.

Hybrid Analog Output Control

Hybrid analog output control, on C450CPW-100 control modules, enables an analog VDC output to transition to a pulse output at low signal levels, providing more efficient low-speed control of variable speed electronically commutated (EC) motors in condenser fan applications.

Network Communications

System 450 communications control modules provide network connectivity and communications. Depending on the communications control module, your control system can connect to and communicate over either Ethernet networks or MODBUS networks. See Table 1 for information on the System 450 control modules with this feature.

Ethernet Communications

System 450 control modules with Ethernet communications have an integral web server that delivers web pages to client browsers on desktop and laptop computers, as well as smart phones, devices, and tablets. The System 450 web UI allows you to monitor your control system status and set up or change the configuration in simple, user-friendly web pages delivered to your computer through a direct connection, a LAN connection, or over the Internet.

Figure 4: System 450 System Overview Page Example

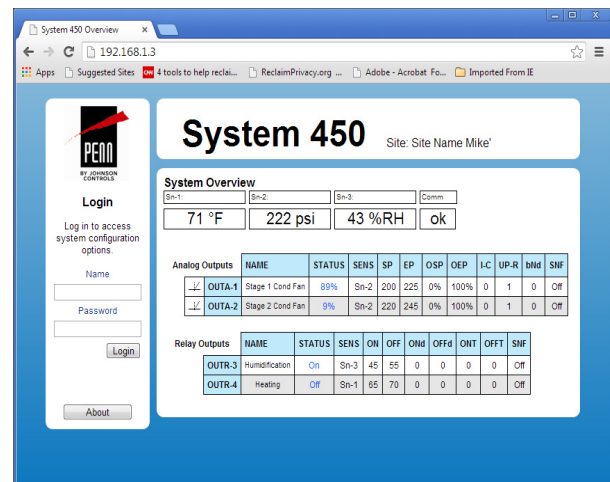

You can monitor control system status and configure the control system parameters in both the local UI (LCD and four-button touchpad) and the web UI.

System 450 control modules with Ethernet communications allow you to:

- directly connect your computer to the System 450 control module with an Ethernet cable, then set up, monitor, and modify your control system
- connect your control system to an existing network and establish a static IP address or use a Dynamic Host Configuration Protocol server to provide a dynamic address

- set up Dynamic Domain Name Server and browse to your System 450 control system on a local network or across the Internet using a text-based URL (host name) instead of a numeric IP address and port number

The System 450 web UI offers easy remote access to your System 450 controls systems across your LAN or across the Internet. The web UI allows you to log in (directly, locally, or remotely) and view the web UI system status, system setup parameters, and parameter values in the UI.

The system configuration web pages allow you to easily set up or change the parameters for your system outputs in the web UI. When the remote access lock feature is activated in the web UI, it allows users to view the control system status, but prevents them from making system changes.

RS485 MODBUS Communications

The System 450 control module with MODBUS communications is an RS485, RTU compliant MODBUS slave device. It allows you to connect your System 450 control system to MODBUS networks and communicate over them.

The System 450 MODBUS communication control module also allows your entire control system to respond to data requests and commands from a MODBUS master device on the MODBUS network.

Table 1: System 450 Control Module Capabilities

Control by _____	System 450 Control Modules			
	Standard	Communications	Reset	Hybrid
	C450CPN-4 C450CQN-4 C450CBN-4 C450CCN-4	C450CEN-1 C450CRN-1	C450RBN-3 C450RCN-3	C450CPW-100
Controlled Condition				
Temperature	X	X	X	X
Pressure	X	X	-	X
Humidity	X	X	X	X
Combination of Conditions	X	X	X	X
Control Capabilities				
On/Off Relay Control	X	X	X	X
Analog Proportional Control (Direct and Reverse Action)	X	X	X	X
Analog Proportional Plus Integral Control (Direct and Reverse Action)	X	X	X	X
Combination of On/Off Relay and Analog Output Control	X	X	X	X
Stand-Alone Control	X	-	X	X
Multi-Stage Control (Relay or Analog)	X	X	X	X
Network Communications	-	X	-	-
High Input Signal Selection	X	X	-	X
Differential Control	X	X	-	X
Output Signal Limiting Output Signal Update Rate Output Signal Deadband	X	X	-	-
Binary Input Control for Relay Outputs	X	X	-	-
On/Off Duration Time Control Minimum On/Off Time On/Off Time Delay	X	X	-	-
Temperature and Humidity Reset Control	-	-	X	-
Scheduling and Temperature Setback Control	-	-	X	-
Reset Setpoint Control	-	-	X	-
Setback Scheduling	-	-	X	-
Run-Time Balancing	-	-	X	-
Hybrid Analog Output Control	-	-	-	X ¹

1. Only on output OUTA1.

System 450 Control Modules

The System 450 control module is the supervisor of your control system and the interface for the system's inputs, supply power, and outputs. Figure 5 shows an example System 450 control module. See Table 1 and Table 2 for information on all of the available control modules.

Figure 5: C450CBN Standard Control Module



All System 450 control systems require a control module for setting up the control system's inputs and outputs, monitoring the control system's status, and controlling the system's outputs.

System 450 control modules are capable of monitoring up to three inputs and controlling up to ten outputs, which can be any combination of relay and analog outputs (provided by expansion modules).

User-Friendly LCD and Touchpad UI

System 450 control modules feature a backlit LCD screen, which during normal operation displays the real-time status of the sensors that are set up in your control system. The four-button touchpad enables you to quickly scroll through and view the output status screens and access the system setup screens to set up or adjust the sensors and outputs in your control system.

After you assemble and power your control system, and select the Sensor Types in the UI, the control module automatically determines the output numbers and output types. The control module then generates the menu-based setup screens and supplies all of the default setup values required to set up your custom control system.

System 450 Standard Control Modules

System 450 standard control modules can be easily configured out of the box as stand-alone controls, which can provide SPDT control or proportional analog signal control (depending on the model) for a wide range of HVACR applications, as well as commercial process and industrial process applications. The following standard control modules are available:

- C450CBN-4 control module has one SPDT relay output
- C450CCN-4 control modules have two SPDT relay outputs
- C450CPN-4 control modules have one analog output (0–10 VDC or 4–20 mA)
- C450CQN-4 control modules have two analog outputs (0–10 VDC or 4–20 mA)

With a standard control module and the available sensors and transducers, almost any temperature, pressure, or humidity control you may encounter in the field can be quickly replaced with a System 450 control system. See Table 1 for capabilities of the standard control modules.

System 450 Reset Control Modules

Reset control modules provide many of the features of the standard control modules for temperature and humidity control. In addition, these modules provide temperature and humidity reset, real-time setback, and run-time balancing capability. The following reset control modules are available:

- C450RBN-3 (one SPDT relay output)
- C450RCN-3 (two SPDT relay outputs)

See Table 1 for capabilities of the System 450 reset control modules.

Reset control modules control temperature and humidity, but not pressure.

System 450 Hybrid Analog Output Control Modules

A System 450 hybrid analog output control module can provide the same control as the standard control modules, while providing a hybrid analog output control option for controlling EC motors.

The hybrid analog output control feature enables an analog VDC output to transition to a pulse output at low signal levels. This provides more efficient low-speed control of electronically commutated (EC) variable speed motors. These EC variable speed motors are typically used in condenser fan applications on a wide variety of refrigeration and HVAC condensing units.

The onboard analog output can also be configured for High Input Signal Selection, which enables precise and efficient EC motor speed control on multi-circuit condensing units.

See Table 1 for capabilities of the System 450 Hybrid Analog Output control modules.

System 450 Control Modules with Communications

A System 450 control module with communications provides the same types of control as the standard control modules. See Table 1 for capabilities of the System 450 control modules with communications.

C450CEN-1 control modules feature an RJ45 Ethernet network port that enables you to connect your control system to an Ethernet network and communicate across it.

C450CRN-1 control modules feature an RS485 terminal block that enables you to connect your control system to an RS485 MODBUS network and communicate on it.

System 450 communications control modules do not provide onboard outputs and require expansion modules to provide outputs.

Other System 450 Components

The System 450 suite of components enables you to build a wide variety of cost-effective, custom control systems that meet your specific application requirements; including multipurpose control systems that control temperature, pressure, and humidity simultaneously.

You do not need to purchase additional and unnecessary features and components associated with packaged control systems, which reduces your control system costs to just the inputs, outputs, and features required by your application.

System 450 components allow you to build control systems that include:

- one to ten outputs provided by the control module and expansion modules, each output providing either on/off control or a proportional analog signal (0 to 10 VDC or 4 to 20 mA) to the equipment in your controlled system
- one to three sensors or transducers, which are hard-wired directly to the control module and provide input signals for monitoring and controlling your system equipment
- an optional power module to provide power to the control module, expansion modules, and the input sensors and transducers

Expansion Modules

Figure 6: C450SCN Relay Expansion Module



System 450 expansion modules allow you to increase the number of outputs in your control system to meet your application requirements. The following models are available:

- C450SBN-3 or C450SBG-3: Relay Expansion module with one relay output
- C450SCN-3 or C450SCG-3: Relay Expansion module with two relay outputs (Figure 6)
- C450SPN-1: Analog Expansion module with one analog output
- C450SQN-1: Analog Expansion module with two analog outputs

For further information, see [Ordering Information](#) and [Technical Specifications](#).

Power Module

Figure 7: C450YNN Power Module



System 450 modules require 24 VAC - Class 2 power. The C450YNN-1 Power module (Figure 7) provides a convenient means of transforming 120/240 VAC to 24 VAC to power System 450 control systems.

System 450 Compatible Sensors and Transducers

System 450 control modules are designed to operate with a variety of compatible sensors and transducers. The System 450 compatible sensors and transducers cover a wide range of temperature, pressure, and humidity conditions.

System 450 compatible sensors and transducers come in a variety of styles and configurations, allowing you to select the sensor or transducer that best fits your control system requirements.

For ease of installation and setup, the Sensor Type that you select in the UI for a sensor or transducer automatically determines the sensed condition, unit of measurement, minimum differential, setup value ranges, and the default setup values for each control system output that references the sensor or transducer.

See Table 4 for compatible A99 Series Temperature Sensors (Figure 8). Refer to the *A99B Series Temperature Sensors Product/Technical Bulletin (LIT-125186)* for further information.

Figure 8: A99B Series Temperature Sensors



See Table 5 for compatible TE-6000 Series temperature sensing elements (Figure 9). Refer to the *TE-6000 Series Temperature Sensing Elements Product Bulletin (LIT-216288)* for further information.

Figure 9: TE-6000-1 Temperature Sensing Element



See Table 6 for compatible TE-6300 Series Temperature Sensors (Figure 10). Refer to the *TE-6300 Series Temperature Sensors Product Bulletin (LIT-216320)* for further information.

Figure 10: TE-6300 Series Temperature Sensors



See Table 7 for compatible TE-6800 Series Wall Mount Temperature Sensors (Figure 11). Refer to the *TE-6800 Series Temperature Sensors Product Bulletin (LIT-12011542)* for more information.

Figure 11: TE-6800 Series Wall Mount Temperature Sensor



See Table 9 for compatible HE-6800 Series Humidity Transmitters with Temperature Sensors (Figure 12). Refer to the *HE-6800 Series Humidity Transmitters with Temperature Sensor Product Bulletin (LIT-12011625)* for more information.

Figure 12: HE-6800 Series Humidity Transmitter with Temperature Sensor



See Table 8 for compatible HE67SE Type humidity sensors with integral A99B temperature sensor (Figure 13). Refer to the *TrueRH™ Series HE-67xx Humidity Element with Temperature Sensors Product Bulletin (LIT-216245)* for more information.

Figure 13: HE67xx Humidity Sensor



See Table 11, Table 12, and Table 13 for compatible P499 Series pressure transducers (Figure 15). Refer to the *P499 Series Electronic Pressure Transducers Product/Technical Bulletin (LIT-12011190, Part No. 24-7664-2659)* for more information.

Figure 15: P499 Series Pressure Transducers



See Table 10 for compatible DPT265 Series low pressure differential transducers (Figure 14). For further information, see the *Setra Systems Model DPT265 Very Low Differential Pressure Transducer Catalog Page* on the Johnson Controls QuickLIT website.

Figure 14: DPT265 Series Low Pressure Differential Pressure Transducers



See Table 14, Table 15, and Table 13 for compatible P598 Series pressure transducers (Figure 16). Refer to the *P598 Series Electronic Pressure Transducers Product/Technical Bulletin (LIT-12012447, Part No. 24-7664-3299)* for more information.

Figure 16: P598 Series Pressure Transducers



System 450 Applications

You can create a wide variety of custom, application-specific control systems with System 450 modules. The following are some common control application examples, most of which can be enhanced by using one of the System 450 control modules with Communication:

- Temperature control
- Pressure control
- Humidity control
- Multipurpose control
- Reset and setback control
- High input-signal selection
- Differential control

Temperature Control

- Temperature monitoring and alarming
- On/Off staged control of boilers and chillers
- Proportional stage control of boilers and chillers
- Boiler and chiller pump control
- Heating and cooling control with deadband
- Floating temperature control of damper and valve actuators
- Cooling tower fan speed/stage control based on water temperature
- Supply, make-up, and mixed air temperature control
- Temperature actuated valve control
- Supply and make-up air damper and fan control
- Condenser fan staging or speed control based on condenser temperature

Refrigerant Pressure Control

- Condenser fan cycling and stage control
- Multispeed condenser fan control
- Floating pressure control of damper and valve actuators
- Condenser fan speed and damper control
- High and low pressure cutout control
- Staged compressor control
- Cooling tower fan speed control based on high-side pressure

- Direct speed control of electronically-commutated (EC) condenser fan motors (C450CPW-100 model)

Other Pressure Control

- Relief damper and fan control for building pressurization
- Constant static pressure control

Humidity Control

- On/Off humidification and dehumidification control
- Proportional humidification and dehumidification control
- Multistage humidification and dehumidification control
- Humidity monitoring and alarming

Multipurpose Control

- Temperature and pressure-based refrigeration rack control
- Temperature and humidity control of wine cellars and greenhouses
- Temperature, humidity, and static pressure control of clean rooms and greenhouses
- Dehumidification with reheat control

Reset Control

- Boiler supply water temperature reset control based on outside air temperature
- Chiller supply water temperature reset control based on outside air temperature
- VAV zone temperature control based on outside air temperature
- Humidity reset based on outside air temperature
- Staged applications with run-time balancing
- Real-time Occupied/Unoccupied setback

High Input Signal Selection

- Pressure-based fan speed or fan cycling control on multi-circuit condensers
- Temperature-based fan speed or fan cycling control on multi-circuit condensers

Differential Control

- Air and fluid pump-flow monitoring and alarming
- Air and fluid filter-status monitoring and alarming
- Chiller barrel flow monitoring, control, and alarming
- Solar air and water heating applications

System 450 Control System Examples

With System 450 control and expansion modules, you can build a wide variety of cost-effective, custom control systems. Each of the following examples is accompanied by an illustration of the module assembly, including wiring diagrams for system sensors and outputs.

For menu flow charts showing typical Main screens and System Status screens, along with System Setup screens and example setup values, refer to one of the following technical bulletins:

- For control systems with standard control modules and the control module with hybrid analog output, refer to the *System 450™ Series Modular Control Systems with Standard Control Modules Technical Bulletin (LIT-12011459)*.

- For control systems with reset control modules, refer to the *System 450™ Series Modular Control Systems with Reset Control Modules Technical Bulletin (LIT-12011842)*.
- For control systems with communications control modules, refer to the *System 450™ Series Modular Control Systems with Communications Control Modules Technical Bulletin (LIT-12011826)*.

Note: The physical configurations, wiring, and setup values shown in the following examples are meant to illustrate typical control system applications and control features. Your control applications may require different modules, module configurations, sensors, and wiring.

Multipurpose Cooling Application with Modbus Communications

Figure 17 shows an example System 450 control system with MODBUS network communications that controls a cooling system and provides condenser fan speed control.

Figure 17: Example System 450 Control with MODBUS Communications Showing a Room Cooling Application with Condenser Fan Speed Control

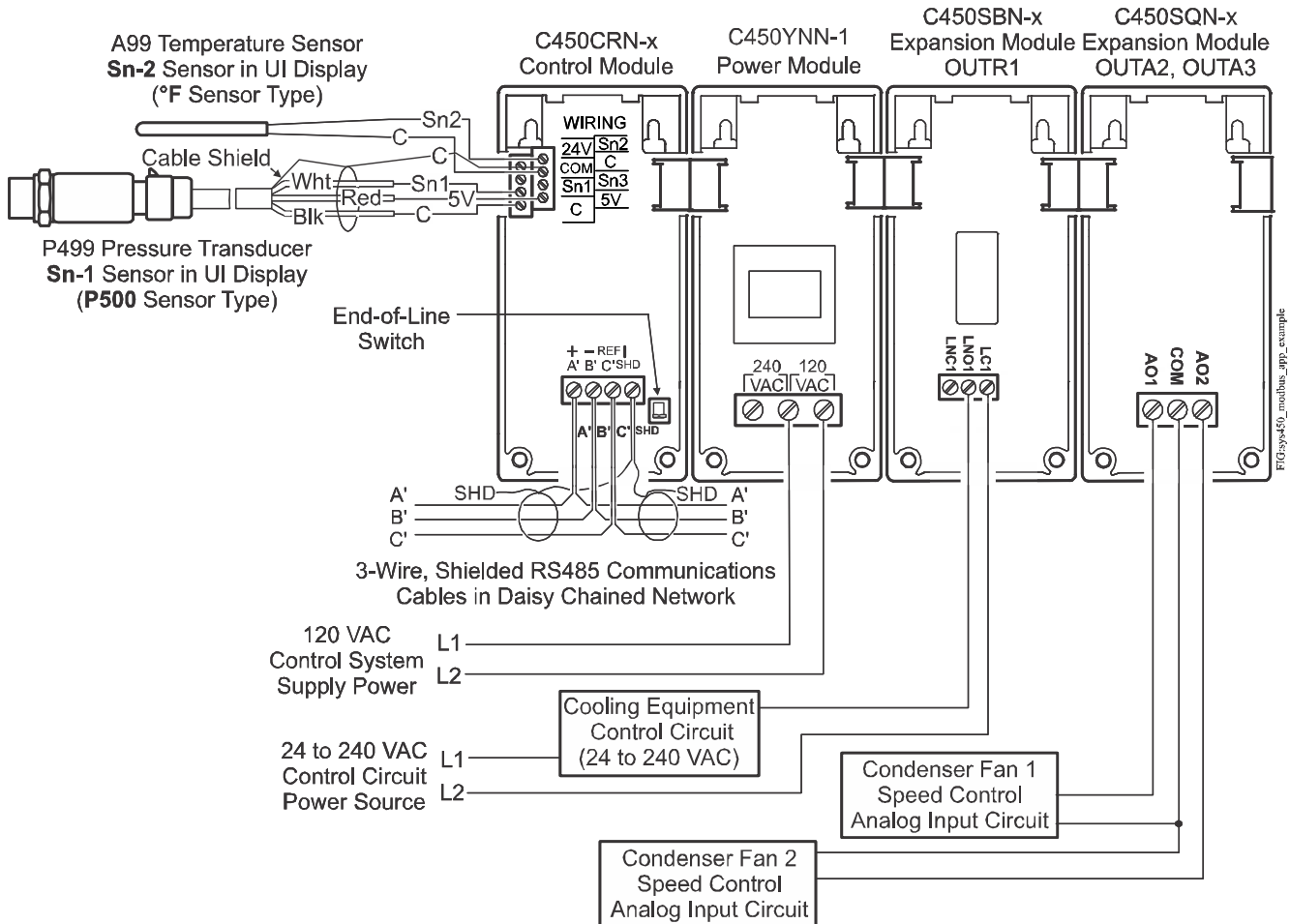

Multipurpose Application for a Clean Room

Figure 18 shows a standard System 450 control system for a clean room application that controls temperature, pressure, and humidity with both relay and analog outputs.

Figure 18: Example System 450 Control Showing a Clean Room Application That Controls Temperature, Pressure, and Humidity Simultaneously

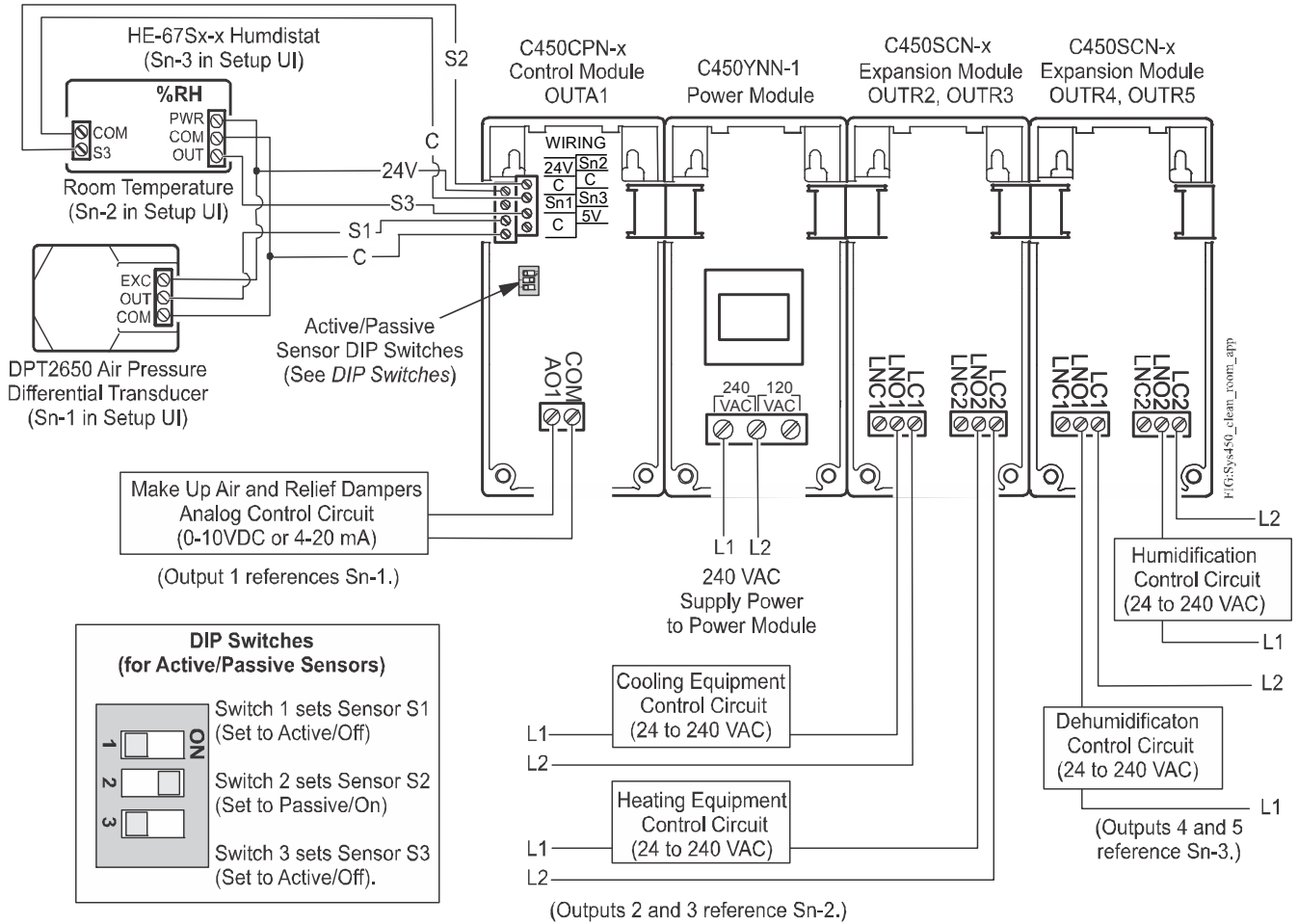

Boiler Water Temperature Reset Example with Three-Stage Boilers

Figure 19 shows a System 450 reset control system that uses an outdoor air temperature master sensor and a supply water temperature sensor configured to reset the boiler supply water temperature relative to the outdoor air temperature. This control system can also be configured to use the run-time balancing feature to equalize the time that each of the three boilers run.

Figure 19: Example System 450 Reset Control System for a Three-Stage Boiler with or without Run-Time Balancing

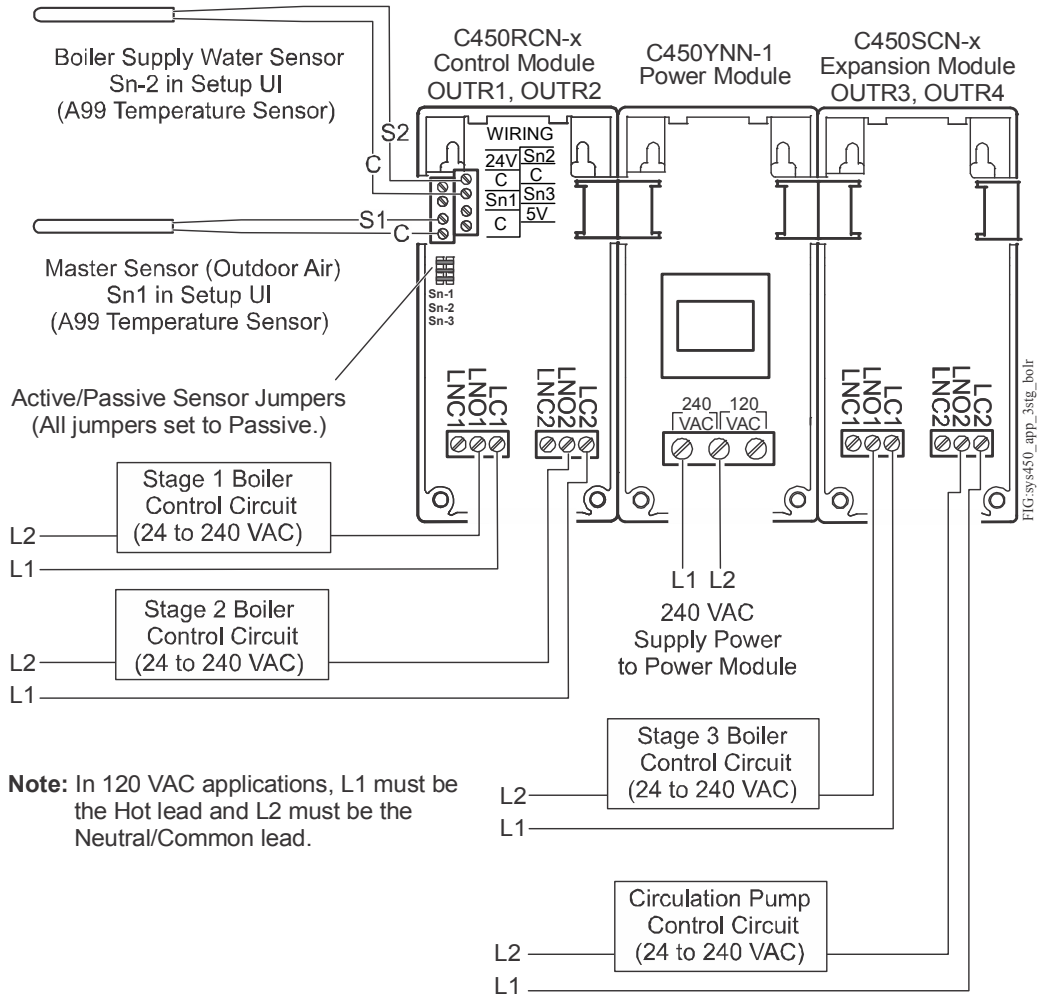

System 450 Solar Water Heating Example with Differential Control

Figure 20 shows a MODBUS System 450 control system example of a solar water heating and storage application that uses the differential control feature to control two circulation pumps.

Figure 20: Example System 450 Control System with Ethernet Communications Showing a Solar Water Heating Application that Uses the Differential Control Feature

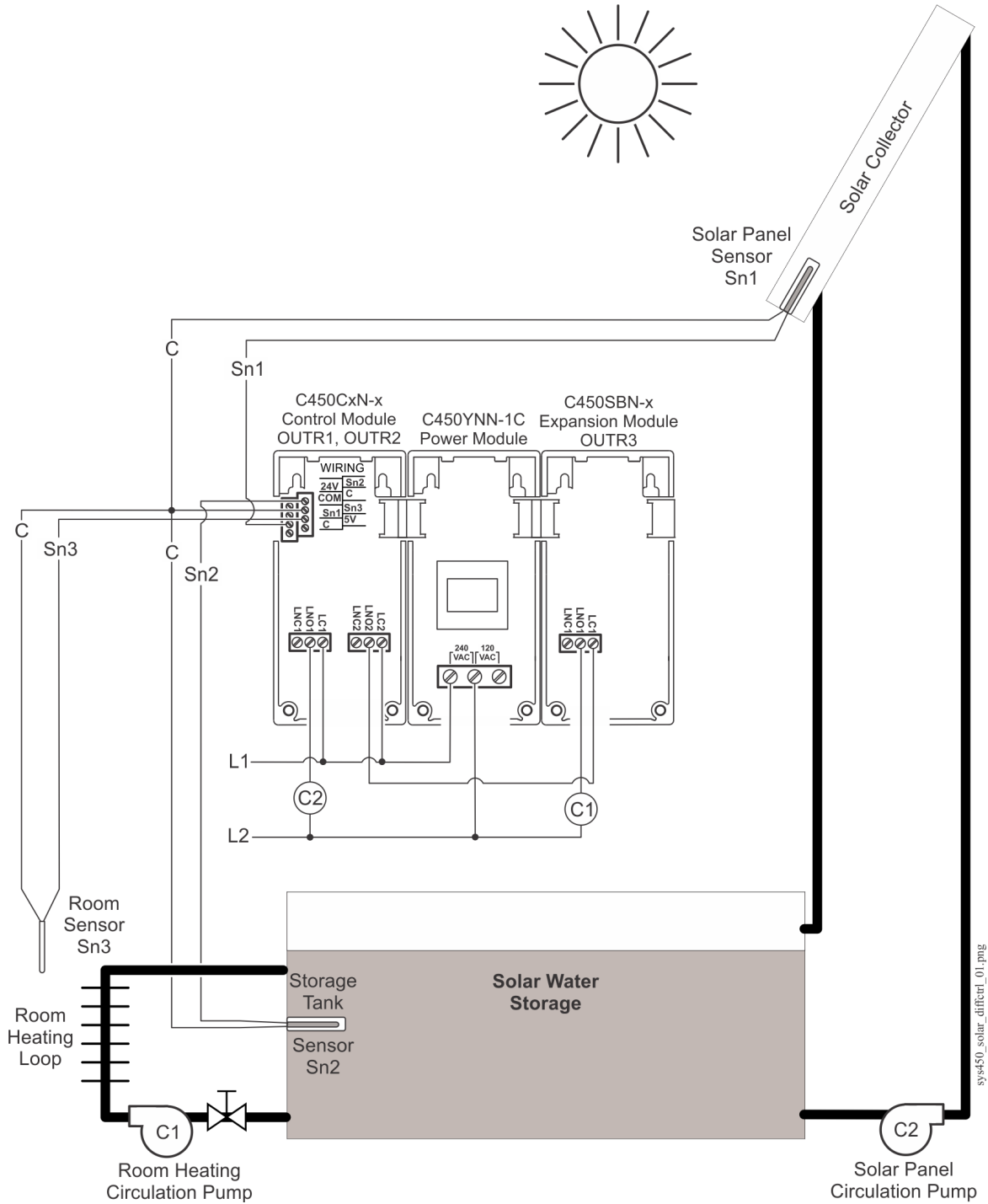

Ordering Information

Table 2: System 450 Modules and Accessories Ordering Information

Product Code Number	Product Description
C450CBN-4	Standard Control Module with LCD, Four-Button Touchpad UI, and Relay Output; provides one relay output (SPDT line-voltage relay) for SPDT control.
C450CCN-4	Standard Control Module with LCD, Four-Button Touchpad UI, and Relay Output; provides two relay outputs (SPDT line-voltage relays) for SPDT control.
C450CPN-4	Standard Control Module with LCD, Four-Button Touchpad UI, and Analog Output; provides one analog output (0–10 VDC or 4–20 mA self-selecting signal) for proportional control.
C450CQN-4	Standard Control Module with LCD and Four-Button Touchpad UI, and Analog Output; provides two analog outputs (0–10 VDC or 4–20 mA self-selecting signals) for proportional control.
C450RBN-3	Reset Control Module with LCD, Four-Button Touchpad UI, and SPDT relay output; provides one SPDT output relay. One A99BC-25C temperature sensor with 0.25 m (9-1/4 in.) silicon leads and one A99BC-300C temperature sensor with 3 m (9 ft 10 in.) silicon leads are included in the box with the Reset Control Module.
C450RCN-3	Reset Control Module with LCD, Four-Button Touchpad UI, and SPDT relay output; provides two SPDT output relays. One A99BC-25C temperature sensor with 0.25 m (9-1/4 in.) silicon leads and one A99BC-300C temperature sensor with 3 m (9 ft 10 in.) silicon leads are included in the box with the Reset Control Module.
C450CEN-1	Control Module with Ethernet Communications, LCD, and Four-Button Touchpad UI. (No onboard outputs available on control modules with network communications capabilities.)
C450CRN-1	Control Module with RS485 MODBUS Communications, LCD, and Four-Button Touchpad UI. (No onboard outputs available on control modules with network communications capabilities.)
C450CPW-100	Hybrid Analog Output Control Module with LCD, Four-Button Touchpad UI, Hybrid Analog Output and Optional High Input Signal Select; provides one hybrid analog output and optional high input signal select primarily used for variable-speed EC motor speed control. Only Analog Output 1 (OUTA1) can be configured as a hybrid analog output and/or use the High Input Signal Selection feature. These features are not available for any of the other outputs in a System 450 control system that uses the C450CPW-100C as the control module.
C450SBN-3	Relay Output Expansion Module; provides one SPDT line-voltage relay output.
C450SCN-3	Relay Output Expansion Module; provides two SPDT line-voltage relay outputs.
C450SBG-3	Relay Output Expansion Module; provides one SPDT low voltage/current output.
C450SCG-3	Relay Output Expansion Module; provides two SPDT low voltage/current relay outputs.
C450SPN-1	Analog Output Expansion Module; provides one analog output (0–10 VDC or 4–20 mA self-selecting signal) for proportional control.
C450SQN-1	Analog Output Expansion Module; provides two analog outputs (0–10 VDC or 4–20 mA self-selecting signals) for proportional control.
C450YNN-1	Power Module; provides 24 V to System 450 Module Assembly; 120 VAC or 240 VAC supply power input terminals.

Table 3: System 450 Mounting Accessories

Product Code Number	Product Description
BKT287-1R	DIN Rail; 0.30 m (12 in.) long
BKT287-2R	DIN Rail; 1 m (39-1/3 in.) long
BKT287-3R	DIN Rail; 0.61 m (24 in.) long
BKT287-4R	DIN Rail; 0.36 m (14 in.) long
PLT344-1R	DIN Rail End Clamps (2 clamps)
WHA-C450-100C	System 450 module connection extension cable, 100 cm (3.3 ft) long

Table 4: System 450 Compatible A99B Temperature Sensors and Accessories Ordering Information¹

Product Code Number	Product Description
A99BA-200C	PTC Silicon Sensor with Shielded Cable; Cable Length 2 m (6-1/2 ft); Sensor Temperature Range: -40 to 120°C (-40 to 250°F) Cable Jacket Temperature Range: -40 to 100°C (-40 to 212°F)
A99BB-25C	PTC Silicon Sensor with PVC Cable; Cable Length 0.25 m (9-3/4 in.); Sensor Temperature Range: -40 to 120°C (-40 to 250°F) Cable Jacket Temperature Range: -40 to 100°C (-40 to 212°F)
A99BB-200C	PTC Silicon Sensor with PVC Cable; Cable Length 2 m (6-1/2 ft); Sensor Temperature Range: -40 to 120°C (-40 to 250°F) Cable Jacket Temperature Range: -40 to 100°C (-40 to 212°F)
A99BB-300C	PTC Silicon Sensor with PVC Cable; Cable Length 3 m (9-3/4 ft); Sensor Temperature Range: -40 to 120°C (-40 to 250°F) Cable Jacket Temperature Range: -40 to 100°C (-40 to 212°F)
A99BB-500C	PTC Silicon Sensor with PVC Cable; Cable Length 5 m (16-3/8 ft); Sensor Temperature Range: -40 to 120°C (-40 to 250°F) Cable Jacket Temperature Range: -40 to 100°C (-40 to 212°F)
A99BB-600C	PTC Silicon Sensor with PVC Cable; Cable Length 6 m (19-1/2 ft); Sensor Temperature Range: -40 to 120°C (-40 to 250°F) Cable Jacket Temperature Range: -40 to 100°C (-40 to 212°F)
A99BC-25C	PTC Silicon Sensor with High Temperature Silicon Cable; Cable Length 0.25 m (9-3/4 in.) Sensor Temperature Range: -40 to 120°C (-40 to 250°F) Cable Jacket Rated for Full Sensor Temperature Range.
A99BC-300C	PTC Silicon Sensor with High Temperature Silicon Cable; Cable Length 3 m (9-3/4 ft) Sensor Temperature Range: -40 to 120°C (-40 to 250°F) Cable Jacket Rated for Full Sensor Temperature Range.
A99BC-1500C	PTC Silicon Sensor with High Temperature Silicon Cable; Cable Length 15 m (49 ft) Sensor Temperature Range: -40 to 120°C (-40 to 250°F) Cable Jacket Rated for Full Sensor Temperature Range.
BOX10A-600R	PVC Enclosure for A99 Sensor; Includes Wire Nuts and Conduit Connector (for Outdoor Sensor)
WEL11A-601R	Immersion Well for A99 Sensor Liquid Sensing Applications
A99-CLP-1	Mounting Clip for A99 Temperature Sensor
ADP11A-600R	Conduit Adaptor, 1/2 in. Snap-Fit EMT Conduit Adaptor (box of 10)
TE-6001-1	Duct Mounting Hardware with Handy Box for A99 Sensor
TE-6001-11	Duct Mounting Hardware without Handy Box for A99 Sensor
SHL10A-603R	Sun Shield (for Use with Outside A99 Sensors in Sunny Locations)

1. Refer to the *A99B Series Temperature Sensors Product/Technical Bulletin (LIT-125186)* on the Johnson Controls® QuickLIT website for more information.

Table 5: System 450 Compatible TE-6000 Series 1,000 Ohm Nickel Temperature Sensors and Accessories Ordering Information

Product Code Number	Product Description
TE-6000-x	TE6000 Series 1,000 ohms at 21°C (70°F) nickel temperature sensors (only). Only the TE-6000-6 sensor can be used for the entire HI°C and HI°F temperature range. Different sensing element packages are available for various applications. For a complete list of compatible 1,000 ohm nickel sensors, including sensor descriptions, technical specifications, and mounting accessories, refer to the <i>TE-6000 Series Temperature Sensing Elements Product Bulletin (LIT-216288)</i> . (System 450 Sensor Types HI°C and HI°F)

Table 6: System 450 Compatible TE-6300 Series 1,000 Ohm Nickel Temperature Sensors and Accessories Ordering Information

Product Code Number	Product Description
TE-631xx-x	TE6300 Series 1,000 ohm at 21°C (70°F) nickel averaging and 1,000 ohm thin-film nickel temperature sensors (only). For a complete list of compatible 1,000 ohm nickel averaging and thin-film nickel sensors, including sensor descriptions, technical specifications, and mounting accessories, refer to the <i>TE-6300 Series Temperature Sensors Product Bulletin (LIT-216320)</i> . (System 450 Sensor Types HI°C and HI°F.)

Table 7: System 450 Compatible TE-68NT-0N00S 1,000 Ohm Nickel Temperature Sensor Ordering Information

Product Code Number	Product Description
TE-68NT-0N00S	TE6800 Series 1,000 ohm at 21°C (70°F) nickel temperature sensor for wall-mount applications. For more information, including sensor description, technical specifications, and mounting accessories, refer to the <i>TE-6800 Series Temperature Sensors Product Bulletin (LIT-12011542)</i> . (System 450 Sensor Types HI°C and HI°F.)

Table 8: System 450 Compatible HE67S3 Type Humidity Sensors with Integral A99B Temperature Sensor Ordering Information¹

Product Code Number	Product Description
HE-67S3-0N0BT	Wall Mount Humidity Sensor with A99B Type Temperature Sensor: 10 to 90% RH; 0 to 60°C (32 to 140°F)
HE-67S3-0N00P	Duct Mount Humidity Sensor with A99B Type Temperature Sensor: 10 to 90% RH; 0 to 60°C (32 to 140°F)

1. The HE-67S3 sensors require 24 VAC input and must use the 0–5 VDC output. Refer to the *TrueRH Series HE-67xx Humidity Element with Temperature Sensors Product Bulletin (LIT-216245)* on the Johnson Controls *QuickLIT* website for more information, including technical specifications and mounting accessories.

Table 9: System 450 Compatible HE6800 Series Humidity Transmitters with Temperature Sensor Ordering Information¹

Product Code Number	Product Description
HE-68N2-0N00WS	Wall Mount Humidity Transmitter with Nickel Temperature Sensor: 10 to 90 ±2% RH; 0 to 55°C (32 to 131°F)
HE-68N3-0N00WS	Wall Mount Humidity Transmitter with Nickel Temperature Sensor: 10 to 90 ±3% RH; 0 to 55°C (32 to 131°F)

1. The HE-6800 transmitters require 24 VAC input and must use the 0–5 VDC output. Refer to the *HE-6800 Series Humidity Transmitters with Temperature Sensor Product Bulletin (LIT-12011625)* on the Johnson Controls *QuickLIT* website for more information, including technical specifications and mounting accessories.

Table 10: System 450 Compatible Low Pressure Differential Transducer Ordering Information^{1 2}

Product Code Number	Product Description
DPT2650-R25B-AB	Low Pressure Differential Transducer: -0.25 to 0.25 in. W.C. (System 450 Sensor Type: P 0.25) ³
DPT2650-0R5D-AB	Low Pressure Differential Transducer: 0 to 0.5 in. W.C. (System 450 Sensor Type: P 0.5)
DPT2650-2R5D-AB	Low Pressure Differential Transducer: 0 to 2.5 in. W.C. (System 450 Sensor Type: P 2.5)
DPT2650-005D-AB	Low Pressure Differential Transducer: 0 to 5.0 in. W.C. (System 450 Sensor Type: P 5)
DPT2650-10D-AB	Low Pressure Differential Transducer: 0 to 10 in. W.C. (System 450 Sensor Type: P 10)

1. Refer to the *Setra Systems Model DPT265 Very Low Differential Pressure Transducer Catalog Page* on the *QuickLIT* website for more information.
2. The DPT265 sensors require 24 VAC input and must use the 0–5 VDC output. Refer to the *Setra Systems Model DPT265 Very Low Differential Pressure Transducer Catalog Page* on the Johnson Controls *QuickLIT* web site for more information.
3. Used only with Communications Control Modules.

Table 11: System 450 Compatible P499 Series Transducers with 1/4 in. SAE 45 Flare Internal Thread with Depressor (Style 47) Ordering Information¹

Product Code Number	Product Description
P499RCPS100C	-10 to 100 psig (sealed for wet and freeze/thaw applications); order WHA-PKD3 type wire harness separately
P499RCPS100K	-10 to 100 psig (sealed for wet and freeze/thaw applications); WHA-PKD3-200C wire harness included
P499RCPS102C	0 to 200 psig (sealed for wet and freeze/thaw applications); order WHA-PKD3 type wire harness separately
P499RCPS102K	0 to 200 psig (sealed for wet and freeze/thaw applications); WHA-PKD3-200C wire harness included
P499RCP-101C	0 to 100 psig; order WHA-PKD3 type wire harness separately
P499RCP-101K	0 to 100 psig; WHA-PKD3-200C wire harness included
P499RCP-105C	0 to 500 psig; order WHA-PKD3 type wire harness separately
P499RCP-105K	0 to 500 psig; WHA-PKD3-200C wire harness included
P499RCP-107C	0 to 750 psig; order WHA-PKD3 type wire harness separately
P499RCP-107K	0 to 750 psig; WHA-PKD3-200C wire harness included

1. The P499 sensors must be powered with the +5 VDC and C terminals and the output is 0.5 to 4.5 VDC. Refer to the *P499 Series Electronic Pressure Transducers Product/Technical Bulletin (LIT-12011190, Part No. 24-7664-2659)* on the Johnson Controls *QuickLIT* website for more information.

Table 12: System 450 Compatible P499 Series Transducers with 1/8 in. 27 NPT External Thread (Style 49) Ordering Information¹ (Part 1 of 2)

Product Code Number	Product Description
P499RAPS100C	-10 to 100 psig (sealed for wet and freeze/thaw applications); order WHA-PKD3 type wire harness separately
P499RAPS100K	-10 to 100 psig (sealed for wet and freeze/thaw applications); WHA-PKD3-200C wire harness included
P499RAPS102C	0 to 200 psig (sealed for wet and freeze/thaw applications); order WHA-PKD3 type wire harness separately
P499RAPS102K	0 to 200 psig (sealed for wet and freeze/thaw applications); WHA-PKD3-200C wire harness included
P499RAP-101C	0 to 100 psig; order WHA-PKD3 type wire harness separately
P499RAP-101K	0 to 100 psig; WHA-PKD3-200C wire harness included

Table 12: System 450 Compatible P499 Series Transducers with 1/8 in. 27 NPT External Thread (Style 49) Ordering Information¹ (Part 2 of 2)

Product Code Number	Product Description
P499RAP-102C	0 to 200 psig; order WHA-PKD3 type wire harness separately
P499RAP-105C	0 to 500 psig; order WHA-PKD3 type wire harness separately
P499RAP-105K	0 to 500 psig; WHA-PKD3-200C wire harness included
P499RAP-107C	0 to 750 psig; order WHA-PKD3 type wire harness separately
P499RAP-107K	0 to 750 psig; WHA-PKD3-200C wire harness included

1. The P499 sensors must be powered with the +5 VDC and C terminals and the output is 0.5 to 4.5 VDC. Refer to the *P499 Series Electronic Pressure Transducers Product/Technical Bulletin (LIT-12011190, Part No. 24-7664-2659)* on the Johnson Controls QuickLIT website for more information.

Table 13: WHA-PKD3 Wire Harnesses Ordering Information¹

Product Code Number	Product Description
WHA-PKD3-200C	Plug and 3-Wire Harness for P499 Electronic Pressure Transducers: 2.0 m (6-1/2 ft) cable
WHA-PKD3-400C	Plug and 3-Wire Harness for P499 Electronic Pressure Transducers: 4.0 m (13 ft) cable
WHA-PKD3-600C	Plug and 3-Wire Harness for P499 Electronic Pressure Transducers: 6.0 m (19-5/8 ft) cable

1. Refer to the *P499 Series Electronic Pressure Transducers Product/Technical Bulletin (LIT-12011190, Part No. 24-7664-2659)* on the Johnson Controls QuickLIT website for more information.

Table 14: System 450 Compatible P598 Series Transducers with 1/4 in. SAE 45 Flare Internal Thread with Depressor (Style 47) Ordering Information¹

Product Code Number	Product Description
P598RCPSN401C	-1 to 8 bar; order WHA-PKD3 type wire harness separately.
P598RCPSN402C	-1 to 15 bar; order WH A-PKD3 type wire harness separately.
P598RCPSN404C	0 to 30 bar; order WHA-PKD3 type wire harness separately.
P598RCPSN405C	0 to 50 bar; order WHA-PKD3 type wire harness separately.
P598RCPSN100C	-10 to 100 psis (sealed for wet and freeze/thaw applications); order WHA-PKD3 type wire harness separately.
P598RCPSN100K	-10 to 100 psis (sealed for wet and freeze/thaw applications); WHA-PKD3-200C wire harness included.
P598RCPSN101C	0 to 100 psig; order WHA-PKD3 type wire harness separately.
P598RCPSN101K	0 to 100 psig; WHA-PKD3-200C wire harness included.
P598RCPSN102C	0 to 200 psis (sealed for wet and freeze/thaw applications); order WHA-PKD3 type wire harness separately.
P598RCPSN102K	0 to 200 psis (sealed for wet and freeze/thaw applications); WHA-PKD3-200C wire harness included.
P598RCPSN105C	0 to 500 psig; order WHA-PKD3 type wire harness separately.
P598RCPSN105K	0 to 500 psig; WHA-PKD3-200C wire harness included.
P598RCPSN107C	0 to 750 psig; order WHA-PKD3 type wire harness separately.
P598RCPSN107K	0 to 750 psig; WHA-PKD3-200C wire harness included.

1. The P598 sensors must be powered with the +5 VDC and C terminals and the output is 0.5 to 4.5 VDC. Refer to the *P598 Series Electronic Pressure Transducers Product/Technical Bulletin (LIT-12012447, Part No. 24-7664-3299)* on the Johnson Controls QuickLIT website.

Table 15: System 450 Compatible P598 Series Transducers with 1/8 in. 27 NPT External Thread (Style 49) Ordering Information¹

Product Code Number	Product Description
P598RAPSN100C	-10 to 100 psis (sealed for wet and freeze/thaw applications); order a WHA-PKD3 type wire harness separately.
P598RAPSN100K	-10 to 100 psis (sealed for wet and freeze/thaw applications); WHA-PKD3-200C wire harness included.
P598RAPSN101C	0 to 100 psig; order a WHA-PKD3 type wire harness separately.
P598RAPSN101K	0 to 100 psig; WHA-PKD3-200C wire harness included.
P598RAPSN102C	0 to 200 psis (sealed for wet and freeze/thaw applications); order WHA-PKD3 type wire harness separately.
P598RAPSN102K	0 to 200 psis (sealed for wet and freeze/thaw applications); WHA-PKD3-200C wire harness included.
P598RAPSN105C	0 to 500 psig; order WHA-PKD3 type wire harness separately.
P598RAPSN105K	0 to 500 psig; WHA-PKD3-200C wire harness included.
P598RAPSN107C	0 to 750 psig; order WHA-PKD3 type wire harness separately.
P598RAPSN107K	0 to 750 psig; WHA-PKD3-200C wire harness included.

1. The P598 sensors must be powered with the +5 VDC and C terminals and the output is 0.5 to 4.5 VDC. Refer to the *P598 Series Electronic Pressure Transducers Product/Technical Bulletin (LIT-12012447, Part No. 24-7664-3299)* on the Johnson Controls *QuickLIT* website.

Table 16: WHA-PKD3 Wire Harnesses Ordering Information¹

Product Code Number	Product Description
WHA-PKD3-200C	Plug and 3-Wire Harness for P598 Electronic Pressure Transducers: 2.0 m (6.5 ft) cable
WHA-PKD3-400C	Plug and 3-Wire Harness for P598 Electronic Pressure Transducers: 4.0 m (13 ft) cable
WHA-PKD3-600C	Plug and 3-Wire Harness for P598 Electronic Pressure Transducers: 6.0 m (19.6 ft) cable

1. Refer to the *P598 Series Electronic Pressure Transducers Product/Technical Bulletin (LIT-12012447, Part No. 24-7664-3299)* on the Johnson Controls *QuickLIT* website.

Technical Specifications

C450CPN-4 and C450CQN-4 Control Modules with Analog Output

Product	C450CPN-4 and C450CQN-4: System 450 Control Module models are sensing controls and operating controls with LCD, four-button touchpad, and SPDT analog output C450CPN-4: Control Module with one analog output C450CQN-4: Control Module with two analog outputs
Power Consumption	C450CPN-4: 1.3 VA maximum using 0–10 V out; 1.5 VA maximum using 4–20 mA out C450CQN-4: 2.0 VA maximum using 0–10 V out; 2.4 VA maximum using 4–20 mA out
Supply Power	Internal Supply Power: C450YNN-1 Power Supply Module External Supply Power: 24 VAC (20–30 VAC) Safety Extra-Low Voltage (SELV) (Europe), Class 2 (North America), 50/60 Hz, 10 VA minimum Note: A System 450 control module or module assembly can use an internal or an external supply power source, but must not be connected to both simultaneously.
Ambient Operating Conditions	Temperature: -40 to 66°C (-40 to 150°F) when using 0–10 VDC outputs; -40 to 40°C (-40 to 104°F) when using 4–20 mA outputs Humidity: Up to 95% RH noncondensing; maximum dew point 29°C (85°F)
Ambient Shipping and Storage Conditions	Temperature: -40 to 80°C (-40 to 176°F) Humidity: Up to 95% RH noncondensing; maximum dew point 29°C (85°F)
Input Signal	0–5 VDC for humidity sensors and static pressure transducers 0.5–4.5 VDC for ratiometric pressure transducers 1,035 ohms at 25°C (77°F) for A99 PTC temperature sensors 1,000 ohms at 21.1°C (70°F) for TE-6xxx Nickel temperature sensors
Analog Output	Voltage Mode (0–10 VDC): 10 VDC maximum output voltage 10 mA maximum output current Requires an external load of 1,000 ohms or more The AO operates in Voltage Mode when connected to devices with impedance greater than 1,000 ohms. Devices that fall below 1,000 ohms may not operate as intended with Voltage Mode applications. Current Mode (4–20 mA): Requires an external load between 0–300 ohms The AO operates in Current Mode when connected to devices with impedance less than 300 ohms. Devices that rise above 300 ohms may not operate as intended with Current Mode applications.
Analog Input Accuracy	Resolution: 14 bits
Control Construction	Independently mounted control, surface mounted with Lexan® 950 enclosure suitable for DIN rail mounting or direct mounting to a hard, even surface.
Dimensions (H x W x D)	127 x 61 x 61 mm (5 x 2-3/8 x 2-3/8 in.)
Weight	C450CPN-4: 195 g (0.43 lb) C450CQN-4: 195 g (0.43 lb)
Compliance	United States: cULus Listed; UL 60730-1, File E27734; FCC Compliant to CFR47, Part 15, Subpart B, Class B Canada: cULus Listed; CAN/CSA-E60730-1, File E27734; Industry Canada (IC) Compliant to Canadian ICES-003, Class B limits Europe: CE Mark – Johnson Controls declares that this product is in compliance with the essential requirements and other relevant provisions of the EMC Directive. Australia and New Zealand: RCM mark, Australia/NZ Emissions Compliant



C450CEN-1 Control Module with Ethernet Communications

Product	C450CEN-1: System 450 control modules are sensing controls and operating controls with LCD and four-button touchpad UI, Ethernet communications capability, and no outputs. C450CEN-1: Control module with Ethernet communications capability
Supply Power	Internal Supply Power: C450YNN-1 Power Supply Module External Supply Power: 24 VAC (20–30 VAC) Safety Extra-Low Voltage (SELV) (Europe), Class 2 (North America), 50/60 Hz, 10 VA minimum Note: A System 450 control module or module assembly can use an internal or an external supply power source, but must not be connected to both simultaneously.
Ambient Operating Conditions	Temperature: -40 to 66°C (-40 to 150°F) Humidity: Up to 95% RH noncondensing; maximum dew point 29°C (85°F)
Ambient Shipping and Storage Conditions	Temperature: -40 to 80°C (-40 to 176°F) Humidity: Up to 95% RH noncondensing; maximum dew point 29°C (85°F)
Input Signal	0–5 VDC; 1,035 ohms at 25°C (77°F) for an A99 PTC Temperature Sensor
Analog Input Accuracy	Resolution: 16 bits
Control Construction	Independently mounted control, surface mounted with Lexan® 950 enclosure suitable for DIN rail mounting or direct mounting to a hard, even surface.
Dimensions (H x W x D)	127 x 63 x 63 mm (5 x 2-3/8 x 2-3/8 in.)
Weight	C450CEN-1: 207 g (0.46 lb)
Compliance 	United States: cULus Listed; UL 60730-1, File E27734; FCC Compliant to CFR47, Part 15, Subpart B, Class B
	Canada: cULus Listed; CAN/CSA-E60730-1, File E27734; Industry Canada (IC) Compliant to Canadian ICES-003, Class B limits
	Europe: CE Mark – Johnson Controls declares that this product is in compliance with the essential requirements and other relevant provisions of the EMC Directive.
	Australia and New Zealand: RCM mark, Australia/NZ Emissions Compliant

C450CRN-1 Control Module with RS485 MODBUS Communications

Product	C450CRN-1: System 450 control modules are sensing controls and operating controls with LCD and four-button touchpad UI and no outputs. This control module is an RS485, RTU compliant MODBUS slave device.
Supply Power	Internal Supply Power: C450YNN-1 Power Supply Module External Supply Power: 24 VAC (20–30 VAC) Safety Extra-Low Voltage (SELV) (Europe), Class 2 (North America), 50/60 Hz, 10 VA minimum Note: A System 450 control module or module assembly can use an internal or an external supply power source, but must not be connected to both simultaneously.
Ambient Operating Conditions	Temperature: -40 to 66°C (-40 to 150°F) Humidity: Up to 95% RH noncondensing; maximum dew point 29°C (85°F)
Ambient Shipping and Storage Conditions	Temperature: -40 to 80°C (-40 to 176°F) Humidity: Up to 95% RH noncondensing; maximum dew point 29°C (85°F)
Input Signal	0–5 VDC; 1,035 ohms at 25°C (77°F) for an A99 PTC Temperature Sensor
Analog Input Accuracy	Resolution: 16 bits
Control Construction	Independently mounted control, surface mounted with Lexan® 950 enclosure suitable for DIN rail mounting or direct mounting to a hard, even surface.
Dimensions (H x W x D)	127 x 63 x 63 mm (5 x 2-3/8 x 2-3/8 in.)
Weight	C450CRN-1: 207 g (0.46 lb)
Compliance	<p>United States: cULus Listed; UL 60730-1, File E27734; FCC Compliant to CFR47, Part 15, Subpart B, Class B</p> <p>Canada: cULus Listed; CAN/CSA-E60730-1, File E27734; Industry Canada (IC) Compliant to Canadian ICES-003, Class B limits</p> <p>Europe: CE Mark – Johnson Controls declares that this product is in compliance with the essential requirements and other relevant provisions of the EMC Directive; CISPR22, class B</p> <p>Australia and New Zealand: RCM mark, Australia/NZ Emissions Compliant</p>



C450CPW-100 Control Module with Hybrid Analog Output

Product	C450CPW-100 System 450 control module is a sensing control and operating control with LCD, four-button touchpad, and analog output with pulse-width modulation capability.
Power Consumption	C450CPW-100: 1.3 VA maximum using 0–10 V out; 1.5 VA maximum using 4–20 mA out
Supply Power	Internal Supply Power: C450YNN-1 Power Supply Module External Supply Power: 24 VAC (20–30 VAC) Safety Extra-Low Voltage (SELV) (Europe), Class 2 (North America), 50/60 Hz, 10 VA minimum Note: A System 450 control module or module assembly can use an internal or an external supply power source, but must not be connected to both simultaneously.
Ambient Operating Conditions	Temperature: -40 to 66°C (-40 to 150°F) when using 0–10 VDC outputs; -40 to 40°C (-40 to 104°F) when using 4–20 mA outputs Humidity: Up to 95% RH noncondensing; maximum dew point 29°C (85°F)
Ambient Shipping and Storage Conditions	Temperature: -40 to 80°C (-40 to 176°F) Humidity: Up to 95% RH noncondensing; maximum dew point 29°C (85°F)
Input Signal	0–5 VDC for humidity sensors and static pressure transducers 0.5–4.5 VDC for ratiometric pressure transducers 1,035 ohms at 25°C (77°F) for A99 PTC temperature sensors 1,000 ohms at 21.1°C (70°F) for TE-6xxx Nickel temperature sensors
Analog Output	Voltage Mode (0–10 VDC): 10 VDC maximum output voltage 10 mA maximum output current Requires an external load of 1,000 ohms or more The AO operates in Voltage Mode when connected to devices with impedance greater than 1,000 ohms. Devices that fall below 1,000 ohms may not operate as intended with Voltage Mode applications. Current Mode (4–20 mA): Requires an external load between 0–300 ohms The AO operates in Current Mode when connected to devices with impedance less than 300 ohms. Devices that rise above 300 ohms may not operate as intended with Current Mode applications.
Analog Input Accuracy	Resolution: 14 bits
Control Construction	Independently mounted control, surface mounted with LEXAN 950 enclosure suitable for DIN rail mounting or direct mounting to a hard, even surface.
Dimensions (H x W x D)	127 x 61 x 61 mm (5 x 2-3/8 x 2-3/8 in.)
Weight	C450CPW-100: 195 g (0.43 lb)
Compliance	United States: cULus Listed; UL 60730-1, File E27734; FCC Compliant to CFR47, Part 15, Subpart B, Class B Canada: cULus Listed; CAN/CSA-E60730-1, File E27734; Industry Canada (IC) Compliant to Canadian ICES-003, Class B limits Europe: CE Mark – Johnson Controls declares that this product is in compliance with the essential requirements and other relevant provisions of the EMC Directive. Australia and New Zealand: RCM mark, Australia/NZ Emissions Compliant



C450CBN-4 and C450CCN-4 Control Modules with Relay Output

Product	C450CBN-4 and C450CCN-4: System 450 Control Module models are sensing controls and operating controls with LCD, four-button touchpad, and SPDT relay output C450CBN-4: Control Module with one SPDT output relay C450CCN-4: Control Module with two SPDT output relays									
Power Consumption	C450CBN-4: 0.9 VA maximum C450CCN-4: 1.3 VA maximum									
Supply Power	Internal Supply Power: C450YNN-1 Power Supply Module External Supply Power: 24 VAC (20–30 VAC) Safety Extra-Low Voltage (SELV) (Europe), Class 2 (North America), 50/60 Hz, 10 VA minimum Note: A System 450 control module or module assembly can use an internal or an external supply power source, but must not be connected to both simultaneously.									
Ambient Operating Conditions	Temperature: -40 to 66°C (-40 to 150°F) Humidity: Up to 95% RH noncondensing; maximum dew point 29°C (85°F)									
Ambient Shipping and Storage Conditions	Temperature: -40 to 80°C (-40 to 176°F) Humidity: Up to 95% RH noncondensing; maximum dew point 29°C (85°F)									
Input Signal	0–5 VDC for humidity sensors and static pressure transducers 0.5–4.5 VDC for ratiometric pressure transducers 1,035 ohms at 25°C (77°F) for A99 PTC temperature sensors 1,000 ohms at 21.1°C (70°F) for TE-6xxx Nickel temperature sensors									
Output Relay Contacts	General: 1/2 HP at 120/240 VAC, SPDT Specific: <table border="1" style="margin-left: 20px;"> <thead> <tr> <th>AC Motor Ratings</th> <th>120 VAC</th> <th>208/240 VAC</th> </tr> </thead> <tbody> <tr> <td>AC Full-load Amperes:</td> <td>9.8 A</td> <td>4.9 A</td> </tr> <tr> <td>Locked-Rotor Amperes:</td> <td>58.8 A</td> <td>29.4 A</td> </tr> </tbody> </table> 10 Amperes AC Non-inductive at 24/240 VAC Pilot Duty: 125 VA at 24/240 VAC	AC Motor Ratings	120 VAC	208/240 VAC	AC Full-load Amperes:	9.8 A	4.9 A	Locked-Rotor Amperes:	58.8 A	29.4 A
AC Motor Ratings	120 VAC	208/240 VAC								
AC Full-load Amperes:	9.8 A	4.9 A								
Locked-Rotor Amperes:	58.8 A	29.4 A								
Analog Input Accuracy	Resolution: 14 bits									
Control Construction	Independently mounted control, surface mounted with LEXAN 950 enclosure suitable for DIN rail mounting or direct mounting to a hard, even surface.									
Dimensions (H x W x D)	127 x 61 x 61 mm (5 x 2-3/8 x 2-3/8 in.)									
Weight	C450CBN-4: 209 g (0.46 lb) C450CCN-4: 222 g (0.49 lb)									
Compliance	United States: cULus Listed; UL 60730-1, File E27734; FCC Compliant to CFR47, Part 15, Subpart B, Class B Canada: cULus Listed; CAN/CSA-E60730-1, File E27734; Industry Canada (IC) Compliant to Canadian ICES-003, Class B limits Europe: CE Mark – Johnson Controls declares that this product is in compliance with the essential requirements and other relevant provisions of the EMC Directive. Australia and New Zealand: RCM mark, Australia/NZ Emissions Compliant									



C450RBN-3 and C450RCN-3 Reset Control Modules with Real-Time Clock and Relay Output

Product	C450RBN-3 and C450RCN-3: System 450 Reset Control Module models are sensing controls and operating controls with LCD, four-button touchpad, and SPDT relay output C450RBN-3: Control Module with one SPDT output relay C450RCN-3: Control Module with two SPDT output relays									
Power Consumption	C450RBN-3: 0.9 VA maximum C450RCN-3: 1.3 VA maximum									
Supply Power	Internal Supply Power: C450YNN-1 Power Supply Module External Supply Power: 24 VAC (20–30 VAC) Safety Extra-Low Voltage (SELV) (Europe), Class 2 (North America), 50/60 Hz, 10 VA minimum Note: A System 450 control module or module assembly can use an internal or an external supply power source, but must not be connected to both simultaneously.									
Ambient Operating Conditions	Temperature: -40 to 66°C (-40 to 150°F) Humidity: Up to 95% RH noncondensing; maximum dew point 29°C (85°F)									
Ambient Shipping and Storage Conditions	Temperature: -40 to 80°C (-40 to 176°F) Humidity: Up to 95% RH noncondensing; maximum dew point 29°C (85°F)									
Input Signal	0–5 VDC for humidity sensors 1,035 ohms at 25°C (77°F) for A99 PTC temperature sensors									
Output Relay Contacts	General: 1/2 HP at 120/240 VAC, SPDT Specific: <table border="1" style="width: 100%; border-collapse: collapse;"> <thead> <tr> <th style="text-align: left;">AC Motor Ratings</th> <th style="text-align: center;">120 VAC</th> <th style="text-align: center;">208/240 VAC</th> </tr> </thead> <tbody> <tr> <td>AC Full-load Amperes:</td> <td style="text-align: center;">9.8 A</td> <td style="text-align: center;">4.9 A</td> </tr> <tr> <td>AC Locked-Rotor Amperes:</td> <td style="text-align: center;">58.8 A</td> <td style="text-align: center;">29.4 A</td> </tr> </tbody> </table> 10 Amperes AC Non-inductive at 24/240 VAC Pilot Duty: 125 VA at 24/240 VAC	AC Motor Ratings	120 VAC	208/240 VAC	AC Full-load Amperes:	9.8 A	4.9 A	AC Locked-Rotor Amperes:	58.8 A	29.4 A
AC Motor Ratings	120 VAC	208/240 VAC								
AC Full-load Amperes:	9.8 A	4.9 A								
AC Locked-Rotor Amperes:	58.8 A	29.4 A								
Clock Accuracy	±4 minutes per year									
Clock Backup Power	12 hours (capacitor reserve)									
Setback Events	One occupied and one unoccupied event per day; 7 day schedule									
Analog Input Accuracy	Resolution: 14 bits									
Control Construction	Independently mounted control, surface mounted with LEXAN 950 enclosure suitable for DIN rail mounting or direct mounting to a hard, even surface.									
Dimensions (H x W x D)	127 x 61 x 61 mm (5 x 2-3/8 x 2-3/8 in.)									
Weight	C450RBN-3: 209 g (0.46 lb) C450RCN-3: 222 g (0.49 lb)									
Compliance	<div style="display: flex; align-items: center;"> <div> <p>United States: cULus Listed; UL 60730-1, File E27734; FCC Compliant to CFR47, Part 15, Subpart B, Class B</p> <p>Canada: cULus Listed; CAN/CSA-E60730-1, File E27734; Industry Canada (IC) Compliant to Canadian ICES-003, Class B limits</p> <p>Europe: CE Mark – Johnson Controls declares that this product is in compliance with the essential requirements and other relevant provisions of the EMC Directive.</p> <p>Australia and New Zealand: RCM mark, Australia/NZ Emissions Compliant</p> </div> </div>									

C450SPN-1 and C450SQN-1 Expansion Modules with Analog Output

Product	C450SPN-1: System 450 Expansion Module with one Analog output C450SQN-1: System 450 Expansion Module with two Analog outputs
Power Consumption	C450SPN-1: 1.1 VA max using 0–10 V out; 1.3 VA maximum using 4–20 mA out C450SQN-1: 1.8 VA max using 0–10 V out; 2.2 VA maximum using 4–20 mA out
Supply Power	Internal Supply Power: C450YNN-1 Power Supply Module External Supply Power: 24 VAC (20–30 VAC) Safety Extra-Low Voltage (SELV) (Europe), Class 2 (North America), 50/60 Hz, 10 VA minimum Note: A System 450 control module or module assembly can use an internal or an external supply power source, but must not be connected to both simultaneously.
Ambient Operating Conditions	Temperature: -40 to 66°C (-40 to 150°F) when using 0 to 10 VDC outputs; -40 to 40°C (-40 to 104°F) when using 4 to 20 mA outputs Humidity: Up to 95% RH noncondensing; maximum dew point 29°C (85°F)
Ambient Shipping and Storage Conditions	Temperature: -40 to 80°C (-40 to 176°F) Humidity: Up to 95% RH noncondensing; maximum dew point 29°C (85°F)
Analog Output	Voltage Mode (0 to 10 VDC): 10 VDC maximum output voltage 10 mA maximum output current Requires an external load of 1,000 ohms or more Note: The AO operates in Voltage Mode when connected to devices with impedance greater than 1,000 ohms. Devices that drop below 1,000 ohms may not operate as intended with Voltage Mode applications.
	Current Mode (4 to 20 mA): Requires an external load between 0 to 300 ohms Note: The AO operates in Current Mode when connected to devices with impedances less than 300 ohms. Devices that exceed 300 ohms may not operate as intended with Current Mode applications.
Control Construction	Independently mounted control, surface mounted with Lexan® 950 enclosure suitable for DIN rail mounting or direct mounting to a hard, even surface.
Dimensions (H x W x D)	127 x 61 x 61 mm (5 x 2-3/8 x 2-3/8 in.)
Weight	C450SPN-1: 150 g (0.33 lb) C450SQN-1: 150 g (0.33 lb)
Compliance 	United States: cULus Listed; UL 60730-1, File E27734; FCC Compliant to CFR47, Part 15, Subpart B, Class B
	Canada: cULus Listed; CAN/CSA-E60730-1, File E27734; Industry Canada (IC) Compliant to Canadian ICES-003, Class B limits
	Europe: CE Mark - Johnson Controls declares that this product is in compliance with the essential requirements and other relevant provisions the EMC Directive.
	Australia and New Zealand: RCM mark, Australia/NZ Emissions Compliant

C450Sxx-3 Expansion Modules with Relay Output

Product	C450SBN-3: System 450 Expansion Module with one SPDT output relay C450SCN-3: System 450 Expansion Module with two SPDT output relays C450SBG-3: System 450 Expansion Module with one SPDT low current/voltage output relay C450SCG-3: System 450 Expansion Module with two SPDT low current/voltage output relays									
Power Consumption	C450SBx-3: 0.8 VA maximum C450SCx-3: 1.2 VA maximum									
Supply Power	Internal Supply Power: C450YNN-1 Power Supply Module External Supply Power: 24 VAC (20–30 VAC) Safety Extra-Low Voltage (SELV) (Europe), Class 2 (North America), 50/60 Hz, 10 VA minimum Note: A System 450 control module or module assembly can use an internal or an external supply power source, but must not be connected to both simultaneously.									
Ambient Operating Conditions	Temperature: -40 to 66°C (-40 to 150°F) Humidity: Up to 95% RH noncondensing; maximum dew point 29°C (85°F)									
Ambient Shipping and Storage Conditions	Temperature: -40 to 80°C (-40 to 176°F) Humidity: Up to 95% RH noncondensing; maximum dew point 29°C (85°F)									
Output Relay Contacts	<p>C450SxN-3 General: 1/2 HP at 120/240 VAC, SPDT Specific: AC Motor Ratings</p> <table border="1"> <thead> <tr> <th></th> <th>120 VAC</th> <th>208/240 VAC</th> </tr> </thead> <tbody> <tr> <td>AC Full-Load Amperes:</td> <td>9.8 A</td> <td>4.9 A</td> </tr> <tr> <td>AC Locked-Rotor Amperes:</td> <td>58.8 A</td> <td>29.4 A</td> </tr> </tbody> </table> <hr/> <p>10 Amperes AC noninductive at 24/240 VAC Pilot Duty: 125 VA at 24/240 VAC</p> <p>C450SxG-3 General: 2 amperes resistive at 48 VDC Pilot Duty: 360VA at 120VAC Recommended dry circuit rating: 400 mW maximum at 28 VAC/VDC</p>		120 VAC	208/240 VAC	AC Full-Load Amperes:	9.8 A	4.9 A	AC Locked-Rotor Amperes:	58.8 A	29.4 A
	120 VAC	208/240 VAC								
AC Full-Load Amperes:	9.8 A	4.9 A								
AC Locked-Rotor Amperes:	58.8 A	29.4 A								
Control Construction	Independently mounted control, surface mounted with Lexan® 950 enclosure suitable for DIN rail mounting or direct mounting to a hard, even surface.									
Dimensions (H x W x D)	127 x 61 x 61 mm (5 x 2-3/8 x 2-3/8 in.)									
Weight	C450SBx-3: 172 g (0.38 lb) C450SCx-3: 186 g (0.41 lb)									
Compliance	<p>United States: cULus Listed; UL 60730-1, File E27734; FCC Compliant to CFR47, Part 15, Subpart B, Class B</p> <p>Canada: cULus Listed; CAN/CSA-E60730-1, File E27734; Industry Canada (IC) Compliant to Canadian ICES-003, Class B limits</p> <p>Europe: CE Mark - Johnson Controls declares that this product is in compliance with the essential requirements and other relevant provisions the EMC Directive.</p> <p>Australia and New Zealand: RCM mark, Australia/NZ Emissions Compliant</p>									



C450YNN-1 Power Supply Module

Product	C450YNN-1: System 450 Power Supply Module; 120 or 240 VAC stepdown to 24 VAC Class 2 (North America) or SELV (Europe), 50/60 Hz, 10 VA minimum
Supply Power	110/120 VAC or 220/240 VAC at 50/60 Hz (100 mA maximum)
Secondary Power	24 VAC, 10 VA
Ambient Operating Conditions	Temperature: -40 to 66°C (-40 to 150°F) Humidity: Up to 95% RH noncondensing; maximum dew point 29°C (85°F)
Ambient Shipping and Storage Conditions	Temperature: -40 to 80°C (-40 to 176°F) Humidity: Up to 95% RH noncondensing; maximum dew point 29°C (85°F)
Control Construction	Independently mounted control, surface mounted with LEXAN 950 enclosure suitable for DIN rail mounting or direct mounting to a hard, even surface.
Dimensions (H x W x D)	127 x 61 x 61 mm (5 x 2-3/8 x 2-3/8 in.)
Weight	C450YNN-1: 390 gm (0.86 lb)
Compliance 	United States: cULus Listed; UL 60730-1, File E27734; FCC Compliant to CFR47, Part 15, Subpart B, Class B
	Canada: cULus Listed; CAN/CSA-E60730-1, File E27734; Industry Canada (IC) Compliant to Canadian ICES-003, Class B limits
	Europe: CE Mark - Johnson Controls declares that this product is in compliance with the essential requirements and other relevant provisions the EMC Directive and the Low Voltage Directive.
	Australia and New Zealand: RCM mark, Australia/NZ Emissions Compliant

The performance specifications are nominal and conform to acceptable industry standards. For application at conditions beyond these specifications, consult Johnson Controls Application Engineering at (414) 524-5535. Johnson Controls shall not be liable for damages resulting from misapplication or misuse of its products.

United States Emissions Compliance

This equipment has been tested and found to comply with the limits for a Class B digital device, pursuant to Part 15 of the FCC Rules. These limits are designed to provide reasonable protection against harmful interference in a residential installation. This equipment generates, uses and can radiate radio frequency energy and, if not installed and used in accordance with the instructions, may cause harmful interference to radio communications. However, there is no guarantee that interference will not occur in a particular installation. If this equipment does cause harmful interference to radio or television reception, which can be determined by turning the equipment off and on, the user is encouraged to try to correct the interference by one or more of the following measures:

- Reorient or relocate the receiving antenna.
- Increase the separation between the equipment and receiver.
- Connect the equipment into an outlet on a circuit different from that to which the receiver is connected.
- Consult the dealer or an experienced radio/TV technician for help.

Canadian Emissions Compliance

This Class (B) digital apparatus meets all the requirements of the Canadian Interference-Causing Equipment Regulations. Cet appareil numérique de la Classe (B) respecte toutes les exigences du Règlement sur le matériel brouilleur du Canada.



www.penncontrols.com

® Johnson Controls and PENN are registered trademarks of Johnson Controls in the United States of America and/or other countries. All other trademarks used herein are the property of their respective owners. © Copyright 2018 by Johnson Controls. All rights reserved.